

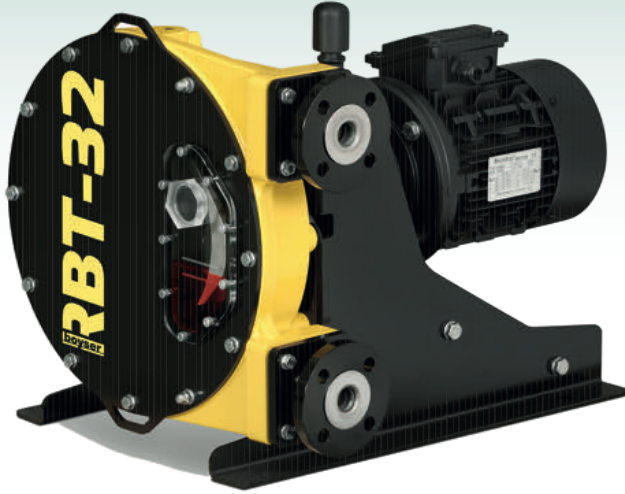

Industrial Peristaltic Pumps

RBT-32/B Data sheet



| | |
|-------------------------|---|
| Capacity: | 0,62 l/rev. |
| Connections: | DN-32 |
| Max. Pressure: | 15 bar |
| Rotor system: | Shoes |
| Available hoses: | NR NBR EPDM HYPALON NR-A NBR-A |

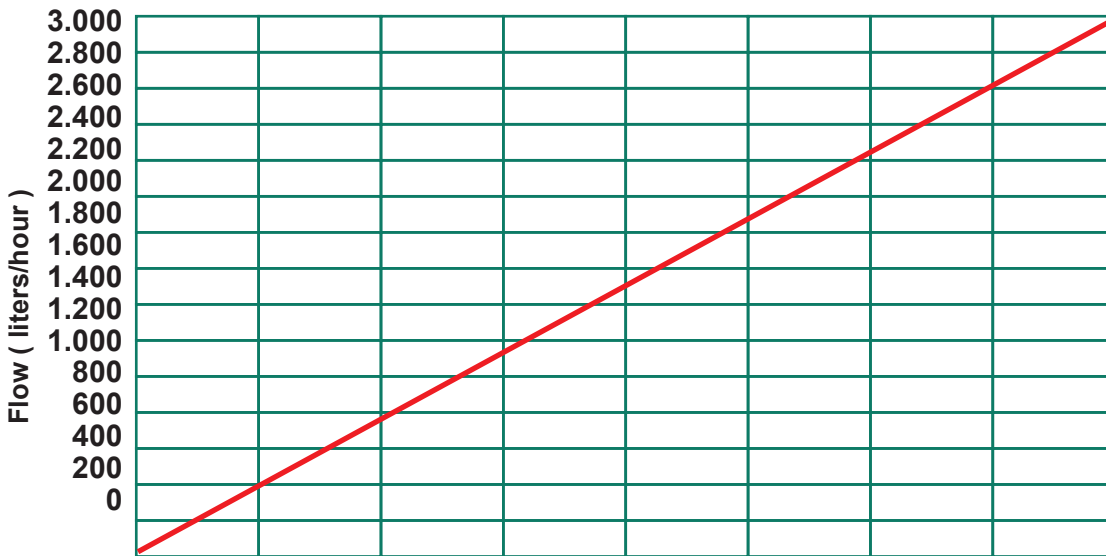

| Pressure (bar) | Torque (Nm) |
|----------------|-------------|
| Minimum | 220 |
| 5 | 220 |
| 7,5 | 220 |
| 10 | 235 |
| 15 | 285 |

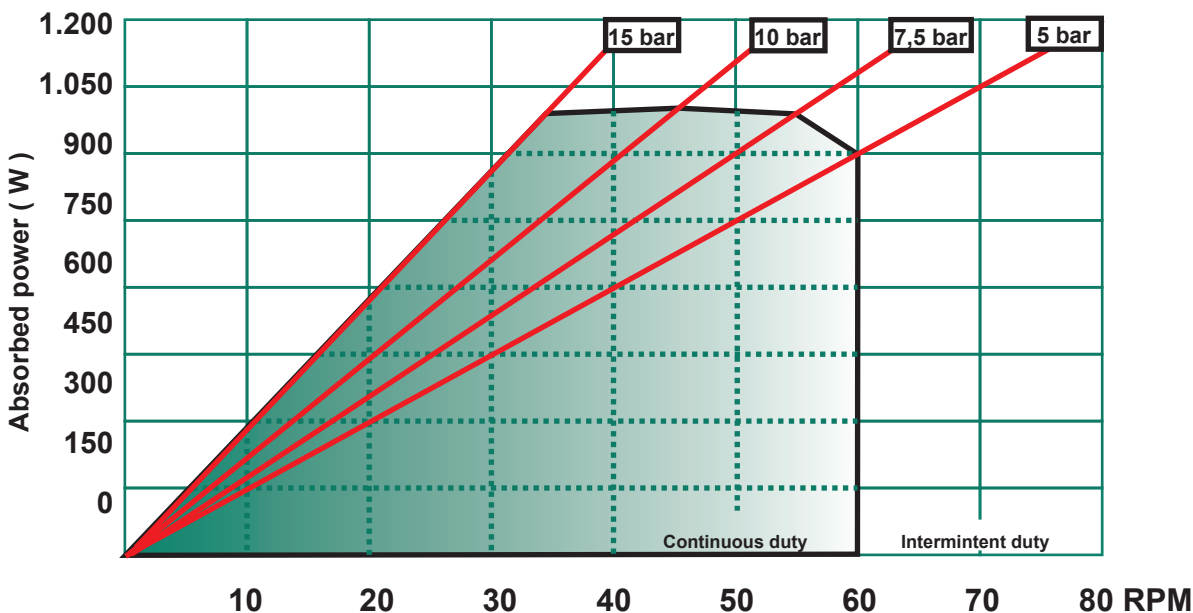

| Description | Material | Surface treatment |
|--------------|---|--|
| Pump housing | Cast Iron EN-GJL-250 | Polyester powder coated Halar coated (Optional) |
| Front cover | Steel F-111 / Methacrilate | Polyester powder coated Halar coated (Optional) |
| Rotor | Nodular Cast Iron EN-GJL-400 | Cataphoresis |
| Shoes | Nodular Cast Iron EN-GJL-400 | Hardened |
| Base plate | Steel F-111 Stainless Steel AISI-304 (Optional) | Polyester powder coated -- |
| Connections | Stainless Steel AISI-316 Polypropylene (Optional) PVDF (Optional) | -- |

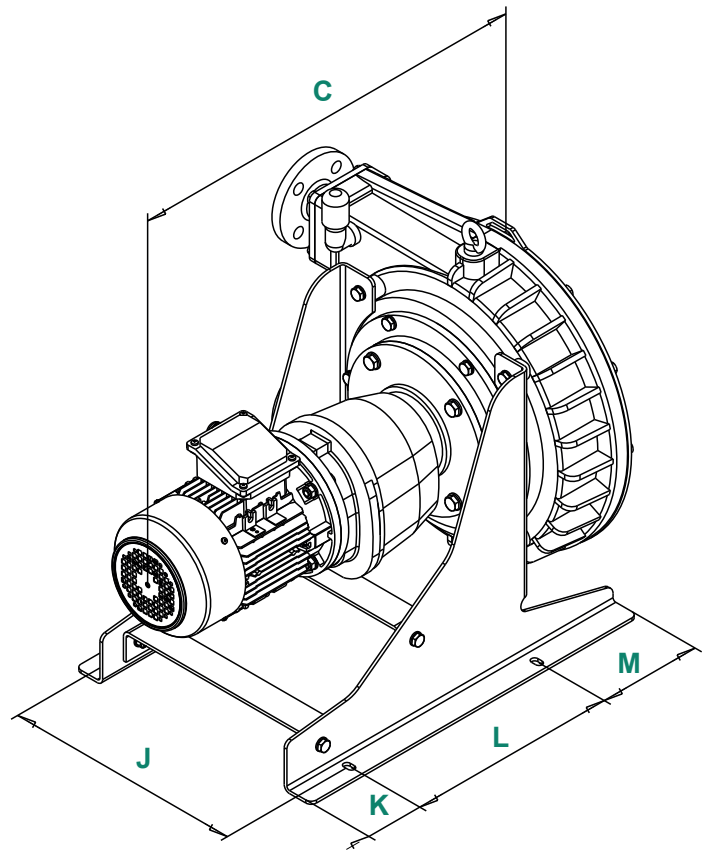
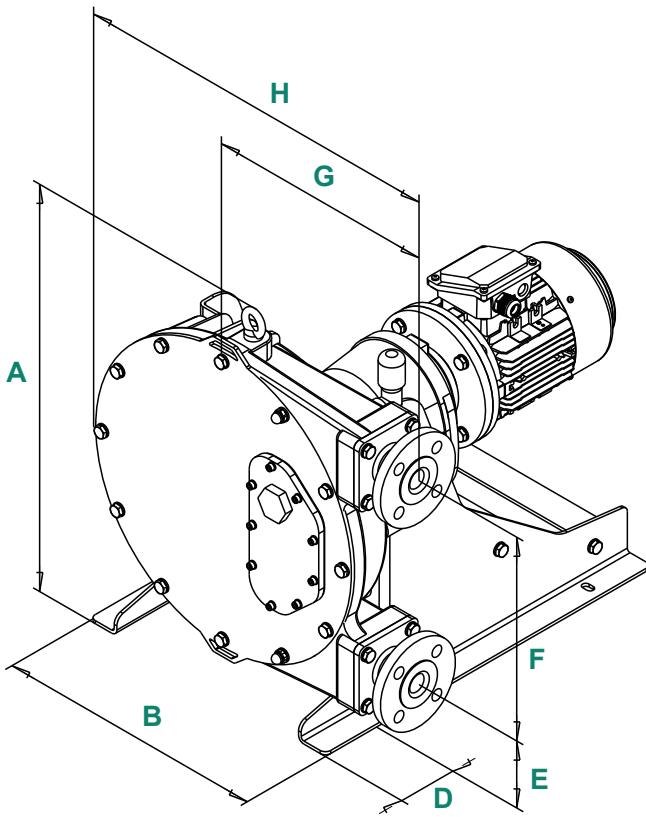

| A | B | C | D | E | F | G | H | J | K | L | M | Connections |
|-----|-----|---|----|-----|-----|-----|-----|-----|----|-----|-----|-------------|
| 580 | 440 | * | 78 | 126 | 300 | 317 | 556 | 400 | 95 | 345 | 170 | DIN DN32 |

* To confirm according type and power driver.



POMPY i SYSTEMY Sp. z o.o.
 ul. Kolibrów 4, 02-818 Warszawa
 tel. 22 549 79 40
 www.pompy.pl | pompy@pompy.pl